

Surveyor		Date		Authority	
Professionals name		Client name			
Address		Address			
Telephone		Telephone			
Email		Email			
Estimate copy to					

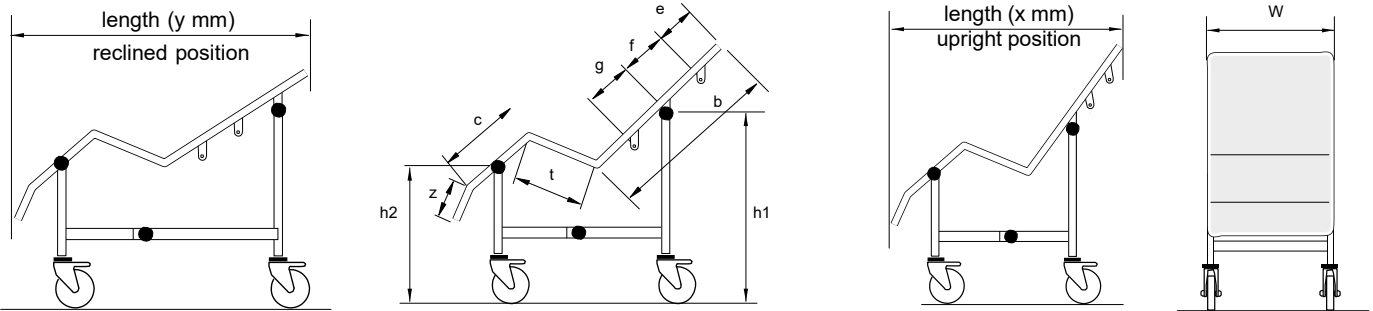

	Small	Medium	Large	Special
h1	815	815	815	
h2	670	670	670	
w	500	500	575	
b	620	750	900	
t	280	350	400	
c	400	480	570	
e	140	150	180	
f	120	150	170	
g	120	150	170	
x	970	1270	1590	
y	1120	1380	1690	
z	150	150	150	

Optional Aperture

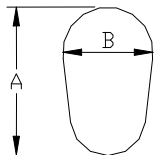

Aperture sizes:	Small	Medium	Large	Other
A	197	240	266	
B	120	165	210	

Additional Requirements

Cot Sides: Head (location b) Leg (location t) Head Support Cushion
 Blue Padded Sleeve Blue Padded Sleeve

Waist Strap*: Velcro Buckle please state length required:

* Waist straps will be located at the rear of the seat section 't' unless otherwise stated.

Other requirements:



Please return completed forms to;
 Chiltern Invadex (UK) Limited, Unit 6C Thorpe Drive, Banbury, Oxon OX16 4UZ
 Email: sales@chilterninvadex.co.uk